

VISION  
Rechargeable Products  
Lead-Acid Battery

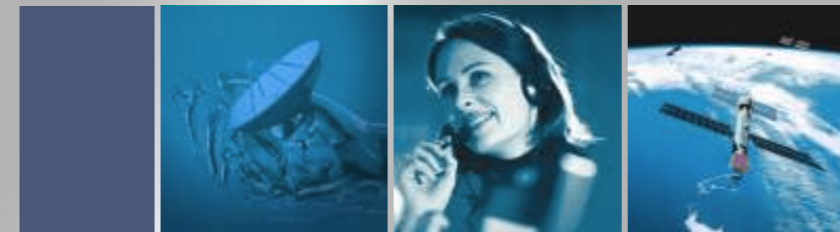

[www.vision-batt.com](http://www.vision-batt.com)



# CT Series

Front Terminal Type  
Products Guide

One of the largest Sealed Lead Acid Battery manufacturers in the world



Center Power Industrial Park, Tongfu Industrial District, Dapeng Town, PC. 518120, Shenzhen, China  
Tel: +86-755-8431 8088 Fax: +86-755-8431 8700  
E-mail: [sales@vision-batt.com](mailto:sales@vision-batt.com) Website: <http://www.vision-batt.com>

(Edition Apr 2008)

Shenzhen Center Power Tech. Co., Ltd

# Contents

|                                       |     |
|---------------------------------------|-----|
| Introduction                          | 1   |
| Features and benefits                 |     |
| Standards                             |     |
| Applications                          | 2   |
| Range Summary                         |     |
| Position of terminals                 | 3   |
| Constraction                          | 4   |
| Performance Data                      | 5-8 |
| Technology                            | 9   |
| Operating Characteristics             | 10  |
| Operating Instructions and Guidelines | 11  |
| Installation and Commissioning Charge | 12  |
| Battery Storage                       | 13  |
| Battery Accommodation                 | 14  |

## Introduction

The new VISION CT series of VRLA batteries has been specially designed for use in telecom systems. With proven compliance to the most rigorous international standards, Such as IEC60896-21/22, BS6290-4, Eurobat Guide, VISION CT series batteries are recognized as the best ones for telecom applications. With front access terminals, it's easy for installing and taking voltage readings during service. The battery container and cover made from V0 class flame retardant ABS & with thick walls, offer the battery with high mechanical strength and safety service features. VISION CT delivers high performance while occupying less space than conventional battery series.

Shenzhen Center Power Tech Co.,Ltd has more than 15 year's experience in the manufacturing of VRLA batteries.

This product guide covers the VISION CT Front Terminal series and is designed to help users select the appropriate battery for particular applications. Technical information includes detailed discharge performance data for each unit and advice on calculating the correct battery size.

The new VISION CT Front Terminal range of valve regulated lead acid batteries has been designed specifically for use in applications where demand the highest levels of security and reliability. With proven compliance to international standards, VISION CT is recognized as one of the best battery series for Telecom/IT applications.

The adoption of gas recombination technology enables lead acid batteries be manufactured in sealed design and maintenance-free. This Technology provides the user with the freedom to use lead acid batteries in a wide range of applications and batteries can be installed in any locations.

The VISION CT Front Terminal batteries are suitable for 19", 23", and ETSI racking, give users the benefit of increased energy density. With all electrical connections at the front, installation and inspection are simpler and quicker.

## Features and benefits



- Thick pasted plates with high quality lead-tin-calcium alloy grids for long service life;
- Centralized venting system for gas ventilation;
- Rope handles for handing and installation convenience;
- Design life 12+ years;

- Easy installation
- Robust copper terminals providing high conductivity, easy connection;
- Front access terminals for easy and quick connection

## Applications

- Communication equipment,
- Uninterruptible power supplies;
- Telecommunication systems;
- Electronic cash registers;
- Microprocessor based office machines;
- Other standby power supplies

## Standards

- IEC60896-21/22
- BS6290-4
- Eurobat Guide
- IEC 707 FV0
- DOT 167





# CT Range Summary

| TYPE      | Nominal Voltage(V) | Capacity to 1.8Vpc@10hr,25°C | L(mm) | L(Inch) | W(mm) | W(Inch) | H(mm) | H(Inch) | TH(mm) | TH(Inch) | Terminal | Wt.(Kg) | Wt.(lbs) |
|-----------|--------------------|------------------------------|-------|---------|-------|---------|-------|---------|--------|----------|----------|---------|----------|
| CT12-50X  | 12                 | 50                           | 277   | 10.9    | 106   | 4.17    | 222   | 8.74    | 229    | 9.02     | M6       | 17.3    | 38.1     |
| CT12-80X  | 12                 | 80                           | 564   | 22.2    | 115   | 4.53    | 189   | 7.44    | 189    | 7.44     | M8       | 28.2    | 62.2     |
| CT12-100X | 12                 | 100                          | 508   | 20.0    | 110   | 4.33    | 223   | 8.78    | 238    | 9.37     | M6       | 32.5    | 71.6     |
| CT12-105X | 12                 | 105                          | 395   | 15.6    | 110   | 4.33    | 286   | 11.3    | 293    | 11.5     | M8       | 35.0    | 77.2     |
| CT12-125X | 12                 | 125                          | 436   | 17.2    | 108   | 4.25    | 317   | 12.5    | 317    | 12.5     | M8       | 41.0    | 90.4     |
| CT12-140X | 12                 | 140                          | 552   | 21.7    | 110   | 4.33    | 288   | 11.3    | 295    | 11.6     | M8       | 49.0    | 108      |
| CT12-150X | 12                 | 150                          | 561   | 22.1    | 105   | 4.13    | 316   | 12.4    | 316    | 12.4     | M8       | 50.4    | 111      |
| CT12-180X | 12                 | 180                          | 546   | 21.5    | 125   | 4.92    | 317   | 12.5    | 323    | 12.7     | M8       | 60.0    | 132      |



CT12-50X



CT12-80X



CT12-100X



CT12-105X



CT12-125X



CT12-140X



CT12-150X



CT12-180X

## Position of terminals

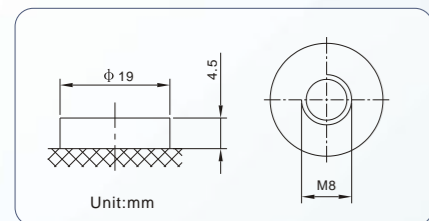

## Construction

### 1. Heavy duty plates

Heavier and thicker plates are pasted from both sides for added durability and a twelve-year design life. Scientific grids designed to resist corrosion and prolong life, special positive grid alloy with pure lead, low calcium and high tin delivers quick high-rate power. Balanced negative plates ensure optimum recombination efficiency.

Tank formed plates ensure full and uniform plate formation optimizing cell voltage balance and performance.

### 2. Advanced Absorbed Glass Mat (AGM) technology.

Utilizes special micro-porous separators to absorb all the electrolyte lowering internal resistance, increasing power, maximizing space utilization and eliminating leaks for safe installation and storage.

Puncture resistant glass mat separators lowers internal resistance for superior high-rate power while protecting against failures and shorts for maximum life.

### 3. High conductivity connectors and terminal

Tin plated, copper threaded insert posts, for easy installation and maintenance ensuring the highest current-carrying capacities. Strong copper threaded insert terminals providing high conductivity and power. The front mounted terminal minimises installation work and makes maintenance very convenient during service.

### 4. High reliable terminal sealing

Epoxy post seal design eliminates post leaks extending battery life and protecting

sophisticated electronic equipment. A proven technology that is 100% factory tested to ensure long life and performance.

### 5. Tough flame retardant cell box

Thick-wall reinforced flame retardant (RATED UL94, V0 28% LOI) ABS resists bulging and meets safety requirements, highly resistant to shock and vibration. Special reinforced design protects battery while providing added heat dissipation capabilities.

### 6. Self-regulating relief valve

Low pressure self-return EPDM Rubber valve prevents ingress of atmospheric oxygen, maximizes gas recombination efficiency and minimizes gassing. Self-sealing valves are 100% factory tested to prevent premature dry-out for dependable battery service. Flame arrestors are installed on all flame-retardant batteries for added safety.

### 7. Lifting handles

All the batteries in the range are provided with rope handles.



# Performance Data

Constant Current Discharge performance

Amperes

| Constant Current Discharge ( Amperes ) at 20°C to 1.60 volts per cell |       |       |       |       |       |       |       |       |       |       |      |      |      |      |      |      |      |      |      |      |      |      |      |      |
|---|-------|-------|-------|-------|-------|-------|-------|-------|-------|-------|------|------|------|------|------|------|------|------|------|------|------|------|------|------|
| Battery Type  | 15min | 20min | 25min | 30min | 35min | 40min | 45min | 50min | 55min | 60min | 1h   | 1.5h | 2h   | 2.5h | 3h   | 4h   | 5h   | 6h   | 7h   | 8h   | 9h   | 10h  | 12h  | 24h  |
| CT12-50X  | 109   | 88.2  | 72.9  | 63.7  | 57.6  | 51.8  | 47.4  | 44.0  | 40.5  | 37.6  | 35.2 | 24.9 | 19.7 | 16.6 | 14.5 | 11.2 | 9.26 | 7.85 | 6.85 | 6.10 | 5.51 | 5.04 | 4.35 | 2.27 |
| CT12-80X  | 174   | 141   | 117   | 102   | 92.1  | 82.8  | 75.8  | 70.4  | 64.8  | 60.1  | 56.3 | 39.8 | 31.5 | 26.5 | 23.2 | 18.0 | 14.8 | 12.6 | 11.0 | 9.75 | 8.82 | 8.07 | 6.97 | 3.63 |
| CT12-100X   | 218   | 176   | 146   | 127   | 115   | 103   | 94.8  | 88.0  | 81.0  | 75.2  | 70.4 | 49.8 | 39.4 | 33.2 | 29.1 | 22.5 | 18.5 | 15.7 | 13.7 | 12.2 | 11.0 | 10.1 | 8.72 | 4.55 |
| CT12-105X   | 229   | 185   | 153   | 134   | 121   | 109   | 99.6  | 92.4  | 85.0  | 78.9  | 73.9 | 52.2 | 41.4 | 34.8 | 30.5 | 23.6 | 19.4 | 16.5 | 14.4 | 12.8 | 11.6 | 10.6 | 9.15 | 4.77 |
| CT12-125X   | 255   | 211   | 175   | 153   | 138   | 123   | 112   | 103   | 95.8  | 89.9  | 85.0 | 60.1 | 47.7 | 40.2 | 35.2 | 27.9 | 23.5 | 20.0 | 17.4 | 15.6 | 14.1 | 12.9 | 11.1 | 5.81 |
| CT12-140X   | 305   | 257   | 210   | 181   | 162   | 144   | 130.5 | 120   | 110   | 101   | 94.4 | 66.9 | 53.1 | 44.8 | 39.3 | 31.3 | 26.5 | 22.5 | 19.6 | 17.4 | 15.7 | 14.4 | 12.4 | 6.48 |
| CT12-150X   |       | 270   | 224   | 196   | 178   | 160   | 147.3 | 137   | 127   | 118   | 111  | 79.1 | 63.1 | 53.5 | 47.1 | 36.5 | 30.2 | 25.3 | 21.7 | 19.1 | 17.0 | 15.4 | 13.3 | 6.93 |
| CT12-180X   |       | 300   | 249   | 218   | 197   | 175   | 158   | 145   | 134   | 125   | 118  | 84.5 | 67.8 | 57.7 | 51.3 | 9.8  | 33   | 28.1 | 24.7 | 22.1 | 20.0 | 18.4 | 15.9 | 8.28 |

| Constant Current Discharge ( Amperes ) at 20°C to 1.65 volts per cell |       |       |       |       |       |       |       |       |       |       |      |      |      |      |      |      |      |      |      |      |      |      |      |      |
|---|-------|-------|-------|-------|-------|-------|-------|-------|-------|-------|------|------|------|------|------|------|------|------|------|------|------|------|------|------|
| Battery Type  | 15min | 20min | 25min | 30min | 35min | 40min | 45min | 50min | 55min | 60min | 1h   | 1.5h | 2h   | 2.5h | 3h   | 4h   | 5h   | 6h   | 7h   | 8h   | 9h   | 10h  | 12h  | 24h  |
| CT12-50X  | 101   | 82.7  | 69.1  | 60.9  | 55.5  | 50.0  | 45.9  | 42.7  | 39.4  | 36.7  | 34.5 | 24.4 | 19.4 | 16.3 | 14.3 | 11.1 | 9.19 | 7.80 | 6.81 | 6.07 | 5.49 | 5.03 | 4.34 | 2.26 |
| CT12-80X  | 161   | 133   | 111   | 98    | 88.7  | 80.0  | 73.4  | 68.3  | 63.1  | 58.8  | 55.2 | 39.1 | 31.0 | 26.1 | 22.9 | 17.8 | 14.7 | 12.5 | 10.9 | 9.71 | 8.79 | 8.05 | 6.95 | 3.62 |
| CT12-100X   | 201   | 165   | 138   | 122   | 111   | 100   | 91.8  | 85.4  | 78.8  | 73.5  | 69   | 48.8 | 38.7 | 32.6 | 28.6 | 22.2 | 18.4 | 15.6 | 13.7 | 12.2 | 11.0 | 10.1 | 8.72 | 4.55 |
| CT12-105X   | 212   | 174   | 146   | 128   | 117   | 105   | 96.5  | 89.7  | 82.8  | 77.1  | 72.4 | 51.3 | 40.7 | 34.3 | 30.1 | 23.4 | 19.3 | 16.4 | 14.3 | 12.8 | 11.6 | 10.6 | 9.15 | 4.77 |
| CT12-125X   | 237   | 200   | 167   | 147   | 134   | 120   | 109   | 101   | 94.1  | 88.5  | 83.8 | 59.4 | 47.1 | 39.8 | 34.9 | 27.7 | 23.3 | 19.8 | 17.3 | 15.4 | 14.0 | 12.8 | 11.1 | 5.76 |
| CT12-140X   | 280   | 239   | 198   | 173   | 156   | 139   | 127   | 117   | 107   | 99.3  | 92.6 | 65.8 | 52.3 | 44.3 | 38.9 | 31.1 | 26.4 | 22.4 | 19.5 | 17.3 | 15.6 | 14.3 | 12.3 | 6.44 |
| CT12-150X   |       | 252   | 212   | 187   | 171   | 155   | 143   | 133   | 123   | 116   | 109  | 77.6 | 61.9 | 52.5 | 46.2 | 35.8 | 29.6 | 24.8 | 21.4 | 18.9 | 16.9 | 15.3 | 13.2 | 6.89 |
| CT12-180X   |       | 285   | 239   | 211   | 192   | 171   | 155   | 143   | 132   | 123   | 116  | 83.2 | 66.7 | 56.9 | 50.3 | 39.4 | 32.8 | 28.0 | 24.5 | 21.9 | 19.9 | 18.3 | 15.8 | 8.24 |

(Note) The above characteristics data are average values obtained within three charge/discharge cycles not the minimum values.

| Constant Current Discharge ( Amperes ) at 20°C to 1.70 volts per cell |       |       |       |       |       |       |       |       |       |       |      |      |      |      |      |      |      |      |      |      |      |      |      |      |
|---|-------|-------|-------|-------|-------|-------|-------|-------|-------|-------|------|------|------|------|------|------|------|------|------|------|------|------|------|------|
| Battery Type  | 15min | 20min | 25min | 30min | 35min | 40min | 45min | 50min | 55min | 60min | 1h   | 1.5h | 2h   | 2.5h | 3h   | 4h   | 5h   | 6h   | 7h   | 8h   | 9h   | 10h  | 12h  | 24h  |
| CT12-50X  | 93    | 77.1  | 65    | 58    | 53.3  | 48    | 44.4  | 41.4  | 38.4  | 35.9  | 33.8 | 24.0 | 19.0 | 16.1 | 14.1 | 11.0 | 9.13 | 7.76 | 6.78 | 6.05 | 5.48 | 5.02 | 4.33 | 2.26 |
| CT12-80X  | 149   | 123   | 104   | 93    | 85.2  | 77.1  | 71.0  | 66.3  | 61.4  | 57.4  | 54   | 38.3 | 30.5 | 25.7 | 22.6 | 17.6 | 14.6 | 12.4 | 10.9 | 9.68 | 8.77 | 8.04 | 6.94 | 3.62 |
| CT12-100X   | 185   | 154   | 131   | 116   | 107   | 96.6  | 88.9  | 82.8  | 76.7  | 71.7  | 67.6 | 47.9 | 38.1 | 32.1 | 28.2 | 22.0 | 18.3 | 15.5 | 13.6 | 12.1 | 10.9 | 10.0 | 8.63 | 4.50 |
| CT12-105X   | 195   | 162   | 137   | 122   | 112   | 101   | 93.3  | 87.0  | 80.6  | 75.3  | 71   | 50   | 39.9 | 33.7 | 29.6 | 23.1 | 19.2 | 16.3 | 14.2 | 12.7 | 11.5 | 10.5 | 9.07 | 4.73 |
| CT12-125X   | 219   | 188   | 160   | 142   | 131   | 117   | 107   | 99    | 92    | 87    | 83   | 59   | 46.6 | 39.4 | 34.6 | 27.5 | 23.2 | 19.7 | 17.2 | 15.3 | 13.9 | 12.7 | 11.0 | 5.72 |
| CT12-140X   | 254   | 221   | 186   | 164   | 150   | 134   | 122   | 113   | 104   | 97    | 91   | 65   | 51.6 | 43.8 | 38.6 | 30.9 | 26.3 | 22.3 | 19.4 | 17.2 | 15.5 | 14.2 | 12.3 | 6.39 |
| CT12-150X   |       | 233   | 199   | 178   | 164   | 149   | 138   | 129   | 120   | 112   | 106  | 76   | 60.5 | 51.4 | 45.3 | 35.1 | 29   | 24.4 | 21.1 | 18.7 | 16.7 | 15.2 | 13.1 | 6.84 |
| CT12-180X   |       | 269   | 228   | 203   | 187   | 167   | 152   | 140   | 130   | 121   | 114  | 82   | 65.6 | 56.0 | 49.5 | 38.9 | 32.6 | 27.8 | 24.4 | 21.8 | 19.8 | 18.2 | 15.7 | 8.19 |

| Constant Current Discharge ( Amperes ) at 20°C to 1.75 volts per cell |       |       |       |       |       |       |       |       |       |       |      |      |      |      |      |      |      |      |      |      |      |      |      |      |
|---|-------|-------|-------|-------|-------|-------|-------|-------|-------|-------|------|------|------|------|------|------|------|------|------|------|------|------|------|------|
| Battery Type  | 15min | 20min | 25min | 30min | 35min | 40min | 45min | 50min | 55min | 60min | 1h   | 1.5h | 2h   | 2.5h | 3h   | 4h   | 5h   | 6h   | 7h   | 8h   | 9h   | 10h  | 12h  | 24h  |
| CT12-50X  | 85    | 71.6  | 61    | 55    | 51.2  | 46    | 42.9  | 40.1  | 37.3  | 35.0  | 33.1 | 23.5 | 18.6 | 15.7 | 13.8 | 10.8 | 9.06 | 7.71 | 6.75 | 6.02 | 5.46 | 5.01 | 4.33 | 2.25 |
| CT12-80X  | 136   | 115   | 98    | 88    | 81.6  | 74.1  | 68.6  | 64.2  | 59.7  | 56.0  | 52.9 | 37.6 | 29.9 | 25.3 | 22.2 | 17.4 | 14.5 | 12.3 | 10.8 | 9.64 | 8.74 | 8.02 | 6.92 | 3.61 |
| CT12-100X   | 169   | 143   | 123   | 110   | 102   | 92.7  | 85.7  | 80.2  | 74.6  | 69.9  | 66.1 | 46.9 | 37.3 | 31.5 | 27.7 | 21.7 | 18.1 | 15.4 | 13.5 | 12.0 | 10.9 | 10.0 | 8.63 | 4.50 |
| CT12-105X   | 178   | 151   | 130   | 117   | 108   | 97.8  | 90.2  | 84.2  | 78.3  | 73.4  | 69   | 49   | 39.3 | 33.2 | 29.2 | 22.8 | 19   | 16.2 | 14.1 | 12.6 | 11.4 | 10.5 | 9.07 | 4.73 |
| CT12-125X   | 201   | 177   | 152   | 137   | 127   | 114   | 105   | 97    | 91    | 86    | 81   | 58   | 46.1 | 39.0 | 34.3 | 27.2 | 23   | 19.5 | 17.1 | 15.2 | 13.8 | 12.6 | 10.9 | 5.67 |
| CT12-140X   | 229   | 203   | 173   | 155   | 143   | 129   | 118   | 110   | 102   | 95    | 89   | 64   | 51.0 | 43.4 | 38.3 | 30.7 | 26.1 | 22.1 | 19.2 | 17.1 | 15.4 | 14.1 | 12.2 | 6.35 |
| CT12-150X   | 235   | 214   | 186   | 168   | 157   | 143   | 133   | 125   | 116   | 109   | 103  | 74   | 59.1 | 50.3 | 44.4 | 34.4 | 28.4 | 24.0 | 20.8 | 18.4 | 16.6 | 15.1 | 13.0 | 6.80 |
| CT12-180X   | 285   | 254   | 218   | 196   | 181   | 163   | 149   | 138   | 127   | 118   | 111  | 80   | 64.4 | 55.0 | 48.8 | 38.5 | 32.3 | 27.6 | 24.2 | 21.7 | 19.7 | 18.1 | 15.6 | 8.15 |

| Constant Current Discharge ( Amperes ) at 20°C to 1.80 volts per cell |       |       |       |       |       |       |       |       |       |       |      |      |      |      |      |      |      |      |      |      |      |      |      |      |
|---|-------|-------|-------|-------|-------|-------|-------|-------|-------|-------|------|------|------|------|------|------|------|------|------|------|------|------|------|------|
| Battery Type  | 15min | 20min | 25min | 30min | 35min | 40min | 45min | 50min | 55min | 60min | 1h   | 1.5h | 2h   | 2.5h | 3h   | 4h   | 5h   | 6h   | 7h   | 8h   | 9h   | 10h  | 12h  | 24h  |
| CT12-50X  | 77.0  | 66.0  | 57.5  | 52.4  | 49.0  | 44.6  | 41.4  | 38.8  | 36.2  | 34.1  | 32.4 | 23.0 | 18.3 | 15.5 | 13.6 | 10.7 | 9.00 | 7.67 | 6.71 | 6.00 | 5.44 | 5.00 | 4.32 | 2.25 |
| CT12-80X  | 122   | 105   | 92    | 83    | 78.1  | 71.2  | 66.1  | 62.1  | 58.0  | 55    | 51.8 | 36.8 | 29.3 | 24.8 | 21.8 | 17.2 | 14.4 | 12.3 | 10.7 | 9.60 | 8.71 | 8.00 | 6.91 | 3.60 |
| CT12-100X   | 153   | 132   | 115   | 105   | 98    | 89.3  | 82.7  | 77.6  | 72.4  | 68    | 64.7 | 46.0 | 36.7 | 31.0 | 27.3 | 21.5 | 18   | 15.3 | 13.4 | 12.0 | 10.9 | 10.0 | 8.63 | 4.50 |
| CT12-105X   | 161   | 139   | 122   | 111   | 104   | 94.4  | 87.1  | 81.5  | 76.1  | 71.6  | 67.9 | 48.3 | 38.5 | 32.6 | 28.7 | 22.6 | 18.9 | 16.1 | 14.1 | 12.6 | 11.4 | 10.5 | 9.07 | 4.73 |
| CT12-125X   | 183   | 165   | 144   | 131   | 123   | 111   | 102   | 95    | 89    | 84.1  | 80.0 | 57.0 | 45.5 | 38.6 | 34   | 27.0 | 22.8 | 19.4 | 16.9 | 15.1 | 13.6 | 12.5 | 10.8 | 5.63 |
| CT12-140X   | 203   | 185   | 161   | 147   | 137   | 124   | 114   | 106   | 98    | 92.2  | 87.0 | 62.5 | 50.3 | 42.9 | 38   | 30.5 | 26   | 22.0 | 19.1 | 17.0 | 15.3 | 14.0 | 12.1 | 6.30 |
| CT12-150X   | 210   | 195   | 172   | 158   | 149   | 137   | 127   | 120   | 112   | 105   | 100  | 71.7 | 57.5 | 49.1 | 43.4 | 33.7 | 27.8 | 23.5 | 20.5 | 18.2 | 16.4 | 15.0 | 13.0 | 6.75 |
| CT12-180X   | 261   | 238   | 207   | 188   | 176   | 158   | 145   | 135   | 125   | 116   | 109  | 78.5 | 63.3 | 54.1 | 48   | 38.1 | 32.1 | 27.4 | 24.0 | 21.5 | 19.6 | 18.0 | 15.5 | 8.10 |

(Note) The above characteristics data are average values obtained within three charge/discharge cycles not the minimum values.



# Performance Data

Constant Power Discharge performance

Watts per cell

| Constant Power Discharge ( Watts per cell ) at 20°C to 1.60 volts per cell |       |       |       |       |       |       |       |       |       |       |     |      |      |      |      |      |      |      |      |      |      |      |      |      |
|--|-------|-------|-------|-------|-------|-------|-------|-------|-------|-------|-----|------|------|------|------|------|------|------|------|------|------|------|------|------|
| Battery Type   | 15min | 20min | 25min | 30min | 35min | 40min | 45min | 50min | 55min | 60min | 1h  | 1.5h | 2h   | 2.5h | 3h   | 4h   | 5h   | 6h   | 7h   | 8h   | 9h   | 10h  | 12h  | 24h  |
| CCT12-50X  | 190   | 159   | 135   | 121   | 111   | 100   | 92.0  | 85.6  | 79.0  | 73.5  | 69  | 48.9 | 38.9 | 32.7 | 28.5 | 22.3 | 18.5 | 15.6 | 13.5 | 11.9 | 10.7 | 9.68 | 8.31 | 4.27 |
| CT12-80X   | 304   | 255   | 217   | 193   | 178   | 160   | 147   | 137   | 126   | 117   | 110 | 78.1 | 62.2 | 52.2 | 45.6 | 35.6 | 29.6 | 24.9 | 21.5 | 19.0 | 17.1 | 15.5 | 13.3 | 6.84 |
| CT12-100X  | 380   | 319   | 271   | 242   | 223   | 201   | 184   | 171   | 158   | 147   | 138 | 97.8 | 77.7 | 65.3 | 57   | 44.6 | 37.1 | 31.2 | 27.0 | 23.8 | 21.4 | 19.4 | 16.6 | 8.56 |
| CT12-105X  | 399   | 335   | 285   | 254   | 234   | 211   | 194   | 180   | 166   | 155   | 145 | 103  | 81.6 | 68.5 | 59.8 | 46.7 | 38.9 | 32.7 | 28.3 | 25.0 | 22.4 | 20.4 | 17.5 | 8.99 |
| CT12-125X  | 450   | 376   | 314   | 277   | 252   | 226   | 207   | 192   | 178   | 167   | 157 | 113  | 90.8 | 76.0 | 66.1 | 52.4 | 44.2 | 37.7 | 33.1 | 29.6 | 26.9 | 24.8 | 21.3 | 10.9 |
| CT12-140X  | 488   | 413   | 343   | 301   | 273   | 246   | 226   | 210   | 194   | 182   | 171 | 124  | 100  | 85.1 | 75.2 | 59.4 | 49.9 | 42.5 | 37.2 | 33.2 | 30.1 | 27.6 | 23.7 | 12.2 |
| CT12-150X  |       | 432   | 365   | 325   | 298   | 269   | 247   | 230   | 214   | 201   | 190 | 142  | 118  | 100  | 88.1 | 69.0 | 57.6 | 48.3 | 41.6 | 36.6 | 32.7 | 29.6 | 25.4 | 13.1 |
| CT12-180X  |       | 525   | 443   | 393   | 360   | 323   | 296   | 274   | 254   | 238   | 225 | 164  | 134  | 112  | 98   | 76.8 | 64.1 | 54.5 | 47.7 | 42.5 | 38.5 | 35.3 | 30.3 | 15.6 |

| Constant Power Discharge ( Watts per cell ) at 20°C to 1.65 volts per cell |       |       |       |       |       |       |       |       |       |       |      |      |      |      |      |      |      |      |      |      |      |      |      |      |
|--|-------|-------|-------|-------|-------|-------|-------|-------|-------|-------|------|------|------|------|------|------|------|------|------|------|------|------|------|------|
| Battery Type   | 15min | 20min | 25min | 30min | 35min | 40min | 45min | 50min | 55min | 60min | 1h   | 1.5h | 2h   | 2.5h | 3h   | 4h   | 5h   | 6h   | 7h   | 8h   | 9h   | 10h  | 12h  | 24h  |
| CT12-50X   | 179   | 151   | 129   | 116   | 107   | 96.6  | 88.8  | 82.7  | 76.5  | 71.4  | 67.1 | 48.0 | 38.4 | 32.3 | 28.2 | 22.1 | 18.4 | 15.5 | 13.4 | 11.8 | 10.6 | 9.66 | 8.29 | 4.27 |
| CT12-80X   | 287   | 242   | 207   | 185   | 171   | 155   | 143   | 133   | 123   | 114   | 107  | 76.7 | 61.5 | 51.7 | 45.2 | 35.4 | 29.5 | 24.8 | 21.5 | 19.0 | 17.0 | 15.5 | 13.3 | 6.83 |
| CT12-100X  | 358   | 303   | 259   | 232   | 214   | 193   | 177   | 165   | 153   | 142   | 134  | 95.9 | 76.8 | 64.6 | 56.5 | 44.2 | 36.8 | 31.0 | 26.9 | 23.7 | 21.3 | 19.4 | 16.6 | 8.56 |
| CT12-105X  | 376   | 318   | 271   | 243   | 224   | 203   | 187   | 174   | 161   | 150   | 141  | 101  | 80.7 | 67.9 | 59.3 | 46.4 | 38.6 | 32.5 | 28.2 | 24.9 | 22.4 | 20.4 | 17.5 | 8.99 |
| CT12-125X  | 428   | 361   | 304   | 269   | 246   | 221   | 203   | 188   | 174   | 163   | 154  | 111  | 89.3 | 75.0 | 65.4 | 52.0 | 43.9 | 37.5 | 32.9 | 29.4 | 26.7 | 24.6 | 21.1 | 10.9 |
| CT12-140X  | 464   | 395   | 330   | 291   | 265   | 239   | 220   | 205   | 190   | 178   | 168  | 122  | 98.8 | 84.0 | 74.2 | 58.7 | 49.4 | 42.1 | 36.9 | 32.9 | 29.9 | 27.5 | 23.6 | 12.1 |
| CT12-150X  |       | 420   | 356   | 318   | 292   | 264   | 243   | 227   | 211   | 199   | 188  | 141  | 117  | 99.1 | 87.2 | 68.4 | 57.1 | 47.9 | 41.3 | 36.3 | 32.5 | 29.4 | 25.2 | 13.0 |
| CT12-180X  |       | 503   | 426   | 380   | 349   | 314   | 288   | 268   | 249   | 234   | 221  | 162  | 132  | 111  | 97   | 76.1 | 63.6 | 54.1 | 47.3 | 42.3 | 38.3 | 35.1 | 30.2 | 15.5 |

(Note) The above characteristics data are average values obtained within three charge/discharge cycles not the minimum values.

| Constant Power Discharge ( Watts per cell ) at 20°C to 1.70 volts per cell |       |       |       |       |       |       |       |       |       |       |      |      |      |      |      |      |      |      |      |      |      |      |      |      |
|--|-------|-------|-------|-------|-------|-------|-------|-------|-------|-------|------|------|------|------|------|------|------|------|------|------|------|------|------|------|
| Battery Type   | 15min | 20min | 25min | 30min | 35min | 40min | 45min | 50min | 55min | 60min | 1h   | 1.5h | 2h   | 2.5h | 3h   | 4h   | 5h   | 6h   | 7h   | 8h   | 9h   | 10h  | 12h  | 24h  |
| CT12-50X   | 168   | 143   | 123   | 110   | 102   | 92.5  | 85.4  | 79.8  | 74    | 69.3  | 65.3 | 47.0 | 37.9 | 32.0 | 28   | 21.9 | 18.2 | 15.3 | 13.3 | 11.8 | 10.6 | 9.64 | 8.27 | 4.26 |
| CT12-80X   | 269   | 230   | 197   | 177   | 164   | 149   | 137   | 128   | 118   | 111   | 104  | 75.1 | 60.7 | 51.2 | 44.8 | 35.1 | 29.2 | 24.6 | 21.3 | 18.9 | 17.0 | 15.4 | 13.2 | 6.82 |
| CT12-100X  | 337   | 286   | 246   | 221   | 205   | 186   | 171   | 160   | 148   | 139   | 131  | 94.3 | 75.9 | 64.0 | 56   | 43.8 | 36.5 | 30.7 | 26.6 | 23.5 | 21.1 | 19.2 | 16.5 | 8.48 |
| CT12-105X  | 354   | 301   | 258   | 232   | 215   | 195   | 180   | 168   | 156   | 145   | 137  | 98.8 | 79.7 | 67.1 | 58.7 | 46.0 | 38.3 | 32.3 | 27.9 | 24.7 | 22.2 | 20.2 | 17.3 | 8.90 |
| CT12-125X  | 406   | 347   | 293   | 261   | 239   | 215   | 198   | 184   | 170   | 159   | 150  | 109  | 87.9 | 74.0 | 64.7 | 51.5 | 43.6 | 37.2 | 32.6 | 29.2 | 26.5 | 24.4 | 20.9 | 10.8 |
| CT12-140X  | 441   | 377   | 318   | 282   | 258   | 233   | 215   | 200   | 186   | 175   | 165  | 120  | 97.5 | 83.0 | 73.3 | 58.1 | 49   | 41.8 | 36.6 | 32.7 | 29.7 | 27.3 | 23.4 | 12.0 |
| CT12-150X  |       | 407   | 347   | 310   | 286   | 259   | 239   | 223   | 208   | 196   | 186  | 139  | 116  | 98.2 | 86.3 | 67.7 | 56.5 | 47.4 | 40.9 | 36.0 | 32.2 | 29.2 | 25.0 | 12.9 |
| CT12-180X  |       | 480   | 410   | 367   | 339   | 306   | 281   | 262   | 244   | 229   | 217  | 159  | 130  | 110  | 96   | 75.4 | 63.1 | 53.7 | 47.0 | 42.0 | 38.1 | 34.9 | 30.0 | 15.4 |

| Constant Power Discharge ( Watts per cell ) at 20°C to 1.75 volts per cell |       |       |       |       |       |       |       |       |       |       |      |      |      |      |      |      |      |      |      |      |      |      |      |      |
|--|-------|-------|-------|-------|-------|-------|-------|-------|-------|-------|------|------|------|------|------|------|------|------|------|------|------|------|------|------|
| Battery Type   | 15min | 20min | 25min | 30min | 35min | 40min | 45min | 50min | 55min | 60min | 1h   | 1.5h | 2h   | 2.5h | 3h   | 4h   | 5h   | 6h   | 7h   | 8h   | 9h   | 10h  | 12h  | 24h  |
| CT12-50X   | 158   | 135   | 116   | 105   | 97.9  | 88.9  | 82.2  | 76.9  | 71.5  | 67.2  | 63.5 | 46.2 | 37.5 | 31.6 | 27.7 | 21.7 | 18.1 | 15.3 | 13.3 | 11.7 | 10.6 | 9.62 | 8.26 | 4.25 |
| CT12-80X   | 252   | 216   | 186   | 168   | 156   | 142   | 131   | 123   | 115   | 108   | 102  | 74   | 60.0 | 50.6 | 44.3 | 34.7 | 29.0 | 24.5 | 21.2 | 18.8 | 16.9 | 15.4 | 13.2 | 6.80 |
| CT12-100X  | 316   | 270   | 233   | 211   | 196   | 178   | 165   | 154   | 143   | 134   | 127  | 92.3 | 75.0 | 63.2 | 55.4 | 43.4 | 36.2 | 30.5 | 26.5 | 23.5 | 21.1 | 19.2 | 16.5 | 8.48 |
| CT12-105X  | 331   | 284   | 245   | 222   | 206   | 187   | 173   | 162   | 150   | 141   | 133  | 96.8 | 78.7 | 66.4 | 58.2 | 45.6 | 38.0 | 32.1 | 27.8 | 24.6 | 22.1 | 20.2 | 17.3 | 8.90 |
| CT12-125X  | 383   | 333   | 283   | 252   | 232   | 209   | 192   | 179   | 166   | 156   | 147  | 107  | 86.4 | 72.9 | 63.9 | 51.0 | 43.2 | 36.9 | 32.3 | 28.9 | 26.3 | 24.2 | 20.8 | 10.7 |
| CT12-140X  | 418   | 358   | 304   | 272   | 250   | 226   | 208   | 194   | 181   | 171   | 162  | 118  | 96.3 | 81.9 | 72.3 | 57.4 | 48.5 | 41.4 | 36.3 | 32.4 | 29.5 | 27.1 | 23.2 | 12.0 |
| CT12-150X  | 440   | 394   | 337   | 303   | 280   | 254   | 234   | 219   | 205   | 194   | 184  | 138  | 115  | 97.2 | 85.3 | 66.9 | 55.9 | 46.9 | 40.5 | 35.7 | 32.0 | 29.0 | 24.9 | 12.8 |
| CT12-180X  | 517   | 458   | 393   | 354   | 328   | 298   | 275   | 257   | 239   | 224   | 212  | 155  | 127  | 108  | 95.0 | 74.7 | 62.5 | 53.3 | 46.6 | 41.7 | 37.8 | 34.8 | 29.8 | 15.3 |

| Constant Power Discharge ( Watts per cell ) at 20°C to 1.80 volts per cell |       |       |       |       |       |       |       |       |       |       |      |      |      |      |      |      |      |      |      |      |      |      |      |      |
|--|-------|-------|-------|-------|-------|-------|-------|-------|-------|-------|------|------|------|------|------|------|------|------|------|------|------|------|------|------|
| Battery Type   | 15min | 20min | 25min | 30min | 35min | 40min | 45min | 50min | 55min | 60min | 1h   | 1.5h | 2h   | 2.5h | 3h   | 4h   | 5h   | 6h   | 7h   | 8h   | 9h   | 10h  | 12h  | 24h  |
| CT12-50X   | 147   | 127   | 110   | 100   | 93.4  | 85.1  | 78.9  | 74.1  | 69.1  | 65.1  | 61.7 | 45.2 | 37.0 | 31.3 | 27.5 | 21.5 | 17.9 | 15.1 | 13.2 | 11.7 | 10.5 | 9.60 | 8.24 | 4.24 |
| CT12-80X   | 235   | 203   | 177   | 161   | 150   | 137   | 127   | 119   | 111   | 104   | 98.8 | 72.5 | 59.3 | 50.1 | 44.0 | 34.4 | 28.7 | 24.3 | 21.1 | 18.7 | 16.8 | 15.4 | 13.2 | 6.78 |
| CT12-100X  | 294   | 254   | 221   | 200   | 187   | 170   | 158   | 148   | 138   | 130   | 123  | 90.4 | 74.1 | 62.6 | 54.9 | 43.0 | 35.9 | 30.3 | 26.4 | 23.4 | 21.1 | 19.2 | 16.5 | 8.48 |
| CT12-105X  | 309   | 267   | 232   | 210   | 196   | 179   | 166   | 156   | 146   | 137   | 130  | 95.2 | 77.8 | 65.7 | 57.7 | 45.2 | 37.7 | 31.9 | 27.7 | 24.5 | 22.1 | 20.2 | 17.3 | 8.90 |
| CT12-125X  | 361   | 318   | 272   | 244   | 225   | 204   | 188   | 175   | 163   | 152   | 144  | 105  | 85.0 | 71.9 | 63.2 | 50.5 | 42.9 | 36.6 | 32.1 | 28.7 | 26.1 | 24.0 | 20.6 | 10.6 |
| CT12-140X  | 395   | 340   | 291   | 262   | 242   | 219   | 202   | 189   | 177   | 167   | 159  | 116  | 95.0 | 80.8 | 71.3 | 56.7 | 48.0 | 41.0 | 35.9 | 32.2 | 29.2 | 26.9 | 23.1 | 11.9 |
| CT12-150X  | 420   | 381   | 327   | 295   | 273   | 248   | 230   | 215   | 201   | 190   | 181  | 136  | 113  | 95.8 | 84.3 | 66.2 | 55.3 | 46.5 | 40.2 | 35.4 | 31.7 | 28.8 | 24.7 | 12.7 |
| CT12-180X  | 492   | 435   | 377   | 341   | 318   | 289   | 268   | 251   | 234   | 220   | 208  | 153  | 125  | 106  | 94.0 | 74.0 | 62.0 | 52.9 | 46.3 | 41.4 | 37.6 | 34.6 | 29.7 | 15.3 |

(Note) The above characteristics data are average values obtained within three charge/discharge cycles not the minimum values.

## Principle of VRLA batteries

During charging of conventional lead acid battery, electrolysis of water occurs at the final stage, then (so) hydrogen generates from the negative plates and oxygen from the positive plates. This causes water loss and periodic watering is needed.

However, evolution of oxygen and hydrogen gases does not occur simultaneously, because the recharge of the positive plates is not as efficient as the negative ones. This means that oxygen is evolved from the positive plate before hydrogen is evolved from the negative plate.

At the same time that oxygen is evolved from the positive plate, a substantial amount of highly active spongy lead exists on the negative plate before it commences hydrogen evolution. Therefore, providing oxygen can be transported to the negative plates, conditions are ideal for a rapid reaction between lead and oxygen, i.e. oxygen is electrochemically reduced on the negative plate according to the following formula,

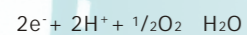

and the final product is water.

The current flowing through the negative plate drives this reaction instead of hydrogen evolution which occur in a conventional battery.

This process is called gas recombination. If this process is 100% efficient no water would be lost from the battery. By careful design and selection of battery components, gas recombination efficiency is between 95% to 99%.

## Principle of the oxygen reduction cycle

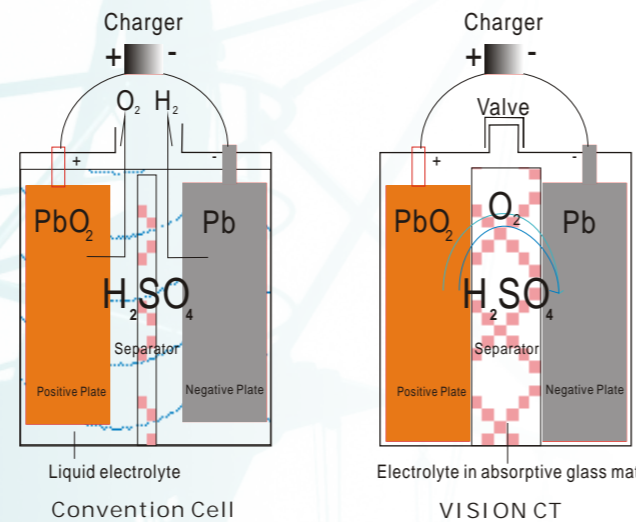

### Conventional Cell

Oxygen and hydrogen escape to the atmosphere.  
VISION CT

Oxygen from the positive plate transfers to the negative and recombines with lead to form water.

### Recombination efficiency

Recombination efficiency is determined under specific conditions by measuring the volume of hydrogen emitted from the battery and converting this into its ampere hour equivalent. This equivalent value is then subtracted from the total ampere hours taken by the battery during the test period, and the remainder is the battery's recombination efficiency and is usually expressed as a percentage.

As recombination is never 100%, some hydrogen gas is emitted from batteries through the safety valve. The volume of gas emitted is very small and typical average values on constant potential float at 20°C are as follows:

| VISION CT hydrogen emissions |  |
|------------------------------|--|
| Float Voltage (V)            | Volume of gas emitted (ml per cell per C <sub>10</sub> Ah per month) |
| 13.5~13.8                    | 3.8  |
| 14.4~14.7                    | 25   |

The VISION CT Front Terminal units should be charged using constant potential chargers.

### Float voltage

At normal room temperature (20°C), the recommended float voltage is equal to 2.25 volts per cell.

To optimise battery performance it is recommended that the float voltage is adjusted for room ambient temperatures in accordance with the following table.

| Temperature | Float voltage range per cell |
|-------------|------------------------------|
| 0°C         | 2.31-2.36V                   |
| 10°C        | 2.28-2.33V                   |
| 20°C        | 2.25-2.30V                   |
| 25°C        | 2.23-2.28V                   |
| 30°C        | 2.22-2.27V                   |
| 35°C        | 2.20-2.25V                   |
| 40°C        | 2.19-2.24V                   |

Under these conditions a recharge will be completed in approximately 72 hours.

### Charging current

A discharged VRLA battery will accept a high recharge current, but for those seeking a more economical charging system a current limit of 0.3 C<sub>10</sub> (A) is adequate.

Note: For a completely discharged battery, 80% of the capacity is replaced in approximately:

- 10 hours at 0.1 C<sub>10</sub>
- 6 hours at 0.3 C<sub>10</sub>
- 5 hours no current limit applied

### Fast recharge

Increasing the charge voltage to 14.4~14.7volts per battery can reduce recharge time and it is possible, depending on the depth of discharge, to halve the recharge time. Under these conditions, however, the charge must be monitored and must be terminated when the charge current remains reasonably steady for 3 consecutive hours after the voltage limit has been reached. At the beginning of charge the current must be limited to 0.3 C<sub>10</sub> (A). This charge regime, in order to achieve a normal service life, must not be used more than once per month

### The effect of temperature on capacity

Correction factors for capacity at different temperatures are shown in the following table, the reference temperature being 20°C.

| Duration of discharge | Battery temperature |       |      |      |      |      |      |      |      |      |      |      |
|-----------------------|---------------------|-------|------|------|------|------|------|------|------|------|------|------|
|                       | -15°C               | -10°C | -5°C | 0°C  | 5°C  | 10°C | 15°C | 20°C | 25°C | 30°C | 35°C | 40°C |
| 15min                 | 0.50                | 0.56  | 0.63 | 0.70 | 0.77 | 0.84 | 0.92 | 1.00 | 1.08 | 1.16 | 1.24 | 1.31 |
| 1 hour                | 0.62                | 0.67  | 0.73 | 0.78 | 0.84 | 0.89 | 0.95 | 1.00 | 1.05 | 1.10 | 1.15 | 1.20 |
| 10hour                | 0.73                | 0.77  | 0.81 | 0.85 | 0.89 | 0.93 | 0.96 | 1.00 | 1.03 | 1.06 | 1.09 | 1.11 |





# Operating Instructions and Guidelines

## Accidental deep discharge

- e.g. (I) Discharge at a lower current for a longer time than the original system specification.
- (II) Failure of the charging system.
- (III) Battery not recharged immediately after a discharge.

## When a battery is completely discharged:

- (I) The utilisation of the sulphuric acid in the electrolyte is total and the electrolyte now consists only of water. During recharge this condition may produce metallic dendrites which can penetrate the separator and cause a short circuit in a cell.
- (II) The sulphation of the plate is at its maximum and the internal resistance of the cell is also at its maximum.

The battery should be recharged under a constant potential of 2.28 volts per cell with the current limited to a maximum of 0.3 C<sub>10</sub>(A) in order to prevent excessive internal heating. For instance, for a CT12-155X the maximum charge current is 46.5 amps. If the sulphation of the cell/battery is extensive, then the recharge of the battery may require more than 96 hours.

*Note: Deep discharging will produce a premature deterioration of the battery and a noticeable reduction in the life expectancy of the battery.*

For optimum operation the minimum voltage of the system should be related to the duty as follows:

| Duty          | Minimum end voltage |
|---------------|---------------------|
| t < 1h        | 1.65V               |
| 1 h < t ≤ 5h  | 1.70V               |
| 5 h < t < 8h  | 1.75V               |
| 8 h < t ≤ 20h | 1.80V               |

In order to protect the battery it is advisable to have system monitoring and low voltage cut-out.

## Float charge ripple

Excessive ripple on the D.C. supply across a battery has the effect of reducing life and performance.

It is recommended therefore, that voltage regulation across the system including the load, but without the battery connected, under steady state conditions, shall be better than ±1% between 5% and 100% load.

Transient and other ripple type excursions can be accommodated provided that, with the battery disconnected but the load connected, the system peak to peak voltage including the regulation limits, falls within ±2.5% of the recommended float voltage of the battery.

Under no circumstances should the current flowing through the battery when it is operating under float conditions, reverse into the discharge mode.

## Electro-Magnetic Compatibility (EMC)

VISION CT products are covered by the EMC statement in prEN 50226:1995 which reads as follows:

Rechargeable cells or batteries are not sensitive to normal electromagnetic disturbances, and therefore no immunity tests shall be required. Free-standing rechargeable cells or batteries electrically isolated from any associated electrical system are for all practical purposes electromagnetically inert, and therefore the requirements for electromagnetic compatibility shall be deemed to be satisfied.

*Note: It should be noted that rechargeable cells or batteries are part of an electrical system, and the manner in which they are used could invoke the requirements of the electromagnetic compatibility upon that system. In such cases, the requirements of electromagnetic compatibility shall be accommodated by the design of the system.*

## Maintenance

- Every month, check that the total voltage at the battery terminals is (N x 2.25V) for a temperature of 20°C.
- N = the number of cells in the battery and 2.25V = 20°C float voltage.
- Once a year, take a reading of the individual bloc voltages in the battery. A variation of ±2.5% on individual voltages from the average voltage is acceptable.
- The system must be checked once or twice a year.

## Principal factors affecting the life of recombination batteries

- Deep discharge
- Poor control of the float voltage
- Cycling or micro-cycling
- Poor quality of charging current (excessive ripple)
- High ambient temperature

# Installation and Commissioning Charge

## Warning

VISION CT Front Terminal units are already charged when delivered.

They should be unpacked with care. Avoid short circuiting terminals of opposite polarity as these units are capable of discharging at a very high current, especially if the lid or the container is damaged.

Acid leakage and unusual appearance must be avoided before switching on, noting open circuit voltage.

There must be appointed man operating for 24 hs after switching on to solving potential problems in time, noting voltage and current.

## Unpacking

It is advisable to unpack all the monoblocs and accessories before commencing to erect and not to unpack and erect monobloc by monobloc.

All items should be carefully checked against the accompanying advice notes to ascertain if any are missing. Advise the Sales Department of any discrepancies.

A rigid plastic insulating cover is provided which totally protects the unit terminals. This is factory fitted to all products of the range and there is no need to remove it until access to the terminals is required.

## Setting up the battery stands

The structure should be assembled in accordance with instructions supplied with the equipment.

To level the stand use the adjustable insulating feet.

## Mounting in a cabinet

Ensure that the cabinet:

- Is sufficiently strong to cope with the weight of the battery.
- Is suitably insulated
- Is naturally ventilated

## Connecting the monoblocs

- Torque setting  
Tighten the nuts or bolts to the recommended levels of torque indicated on the product label.

Always use insulated tools for fitting and torquing up battery connections.

- In series**  
The number of cells in series (N) will not affect the selected float voltage per cell.  
Therefore, charging float voltage = N x Cell float Voltage  
No special circuit arrangements are required.
- In parallel**  
Using constant voltage chargers, and ensuring that the connections made between the charger and the batteries have the same electrical resistance, no special arrangements have to be made for batteries in parallel. Although no special circuit arrangements are required, where the parallel connection is made at the charger or distribution board, to avoid out of step conditions, the bus bar run length and the area of cross section should be designed so that the circuit resistance value for each string is equal within limits ±5%.  
There is no technical reason for limiting the number of strings but for practical installation reasons. It is recommended not allowed to exceed 3 strings in parallel especially if the battery is used in high discharge rates (backup time less than 15 mins)

## General recommendations

- Do not wear clothing of synthetic material to avoid static generation.
- Use only a clean soft damp cloth for cleaning the monoblocs. Do not use chemicals or detergents.
- Use insulated tools.
- Commence installation at the least accessible point.
- Consult the drawing for the correct position of the monobloc poles.

## Commissioning charge

Ensure that the batteries will be operated in a clean environment.

Before use, the batteries should be charged at a constant float voltage adjusted according to the ambient temperature, e.g. 13.5~13.8V/battery at 20°C for 48 to 96 hours or, alternatively, a voltage of 14.4~14.7V/battery at 20°C can be used to reduce the commissioning period from 24 to 15 hours.

Where the batteries have been stored under harsh conditions, this increased voltage recharge is particularly effective.



## Battery Storage

### Storage conditions

Store the battery in a dry, clean and preferably cool location.

### Storage time

As the batteries are supplied charged, storage time is limited. In order to easily charge the batteries after prolonged storage, it is advisable not to store batteries for more than:

- 6 months at 20°C
- 3 months at 30°C
- 6 weeks at 40°C

### Battery state of charge

The battery state of charge can be determined by measuring the open-circuit voltage of cells in rest position for 24 hours at 20°C.

| State of charge | Voltage |
|-----------------|---------|
| 100%            | 2.14Vpc |
| 80%             | 2.10Vpc |
| 60%             | 2.07Vpc |
| 40%             | 2.04Vpc |
| 20%             | 2.00Vpc |

Open circuit voltage variation with temperature is 25mV per 10°C.

### Recharge of stored batteries

A refreshing charge shall be performed after this time at 13.5-13.8V/ battery at 20°C for 48 to 96 hours.

A current limit is not essential, but for optimum charge efficiency the current output of the charger can be limited to 20% of the 10-hour rated capacity.

The necessity of a refreshing charge can also be determined by measuring the open circuit voltage of a stored battery. Refreshing charge is advised if the voltage drops below 2.10 volts per cell.

Failure to observe these conditions may result in greatly reduced capacity and service life.



## Battery Accommodation

The VISION Front Terminal battery's compact design and standard footprint, suitable for 19" 23" and ETSI racking, give users the benefit of increased energy density.

With all electrical connections at the front, installation and inspection are simpler and quicker.

